

Business System Functionability¹

- Mirce Mechanics winning Methods & Formulas

Planned Business System Functionability

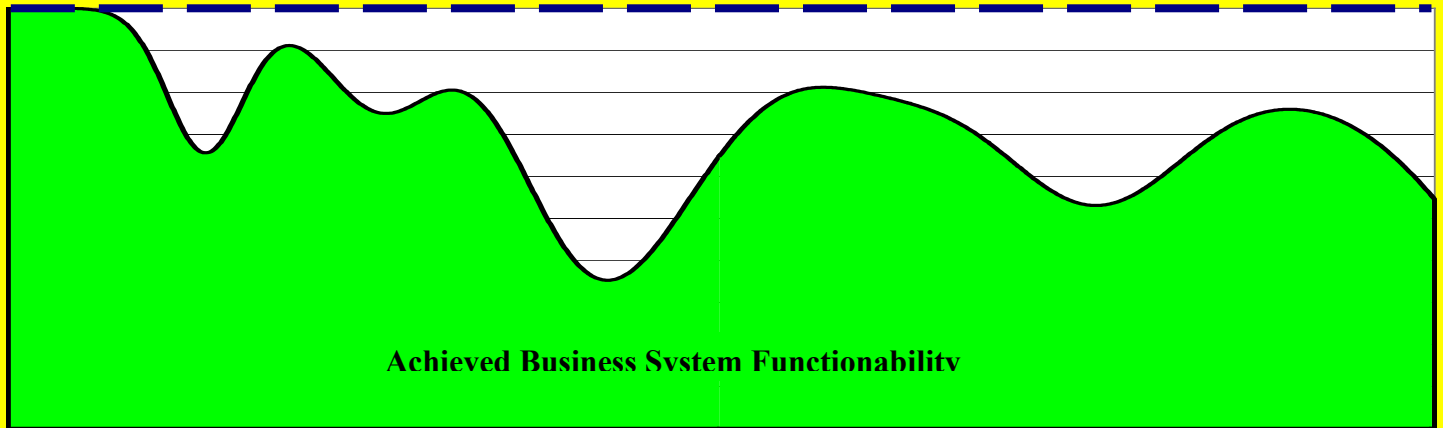

The main task of any business engineer, planner or manager is to make decisions. At every stage and every level in the system life, they have to make a single choice decision from a number of alternative courses of action presented. Some decisions benefit reliability, but at the same time increase production cost. Others improve power-to-weight ratio but increase the number of Not-Fault-Found events or Turn-Around-Cycle, for example. Daily, business engineers and managers strive for decisions that will enhance system in-service performance in one hand and reduce business cost and risk on the other. Hence, there is always a trade-off to be made between business system alternatives regarding investments in research and development and business process returns (profit, reputation, etc).

With the continuous increase in **complexity of modern systems and technologies**, relying solely on the innate ability of engineers and project managers to make critical decisions has become ineffective. Perhaps the main reason is that is the presence of uncertainty, as whenever a decision is made it will only affect the future outcomes. So the business engineers, managers and planners must be always interested in the accuracy of their current predictions in respect to the risk taken for the future consequences.

The aim of the Summer School is to expose business engineering community to the science based Mirce Mechanics methods and formulas for the accurate predictions of business system functionability matrix (throughput, reliability, cost) which are applicable from the initial states of the business systems creation to the planning and management of their operational, maintenance and support processes and challenges.

Material presented at the **Summer School** is applicable to **Vodafone's** mobile phone global business, **BAe System's** military aircraft business, **Rolls Royce's** marine, defence and aerospace business, **General Dynamics'** armoured vehicles, **French Ferries'** transportation business, **Royal Dutch Shell's** Oil Industry Businesses, **Lufthansa's** air transport business, **British Gas's** future business, **Augusta Westland's** helicopter business, **Airbus's** products life support, **National Grid's** sustainability technology, **NHS's** businesses, **IKEA's** international business processes, **Honda's** motor vehicle production lines, **Tesco's** multi dimensional businesses, **Centrica's** business portfolio, **GKN's** global engineering businesses, and of course **MIRCE Akademy's** research and educational business.

¹ Functionability, n, ability of being functional, term defined by J. Knezevic in Reliability, Maintainability and Supportability, a probabilistic approach, pp. 298, McGraw Hill, London, 1992, ISBN 0-07-707691-5.

Dr Jezdimir Knezevic



Researcher, educator and entrepreneur with over 300 publications disseminated world-wide through books, handbooks, papers, monographs and reports are attributed to his name. In addition, he has delivered hundreds of technical presentations, key note addresses and speeches; has been congress, conference, symposium chairman, track leader, workshop presenter, round table moderator on many hundreds international events which took part in all continents.

Dr Knezevic is the father of **Mirce Mechanics**, the science of the motion of system functionability through business process. He is the Founder and President of MIRCE Akademy, an independent research and educational institution based in UK.

His multi-disciplinary theoretical knowledge, considerable “hands-on” practical experience and endless passion for the subject have attracted over 6000 engineers, managers and students to his courses and educational programmes in over 40 countries in Europe, North and South America, Asia, Australia and Africa, at universities, professional institutions, industry and government.

Dr Knezevic has worked in the field of the system functionability theory and its applications to engineering and management for over 30 years.

Full details www.mirceakademy.com

At the MIRCE Akademy we have discovered and faced this problem for many years. During our extensive research studies, by numerous students and members of staff, we have observed and analysed large number of failure phenomena - inherent failures, maintenance errors, foreign object damage, as-bad-as-old repairs, not fault found, ageing processes, storage and transport related phenomena, fatigue cracks, impact of solar radiation, sand, wind, ice on machine durability, material vacancies and many, many more. These failure phenomena required visual checks, inspections, operational tests, non-destructive tests, reliability parameter and indicator monitoring, failure data recording and analysis and those phenomena demanded spares parts, facilities, test equipments, tools and similar resources. We have understood a large number of failure causes, frequencies, and the consequences of their occurrences by studying lives of a large number of business systems. We have quantitatively determined and analytically formulated their relationships. Finally, their **physical relationships** have been captured and described through **mathematical formulas** that enable accurate predictions to be made. All of that has given birth to the *Mirce Mechanics, the scientific theory of the motion of system functionability through business process.*

On this occasion we would like to share our knowledge with practising engineers and managers whose business pressure is preventing them from doing this type of research, but who are never the less asked daily to deliver this type of requirements or expectations.

Programme

Day One

Focuses on the scientific understanding of the business processes and mechanisms that cause the occurrence of functionability events that in turn cause the motion of business system through functionability states. Occurrence of functionability events results from complex interactions between the systems physical properties, natural environment and human actions. Thus, functionability phenomena that cause occurrence of positive and negative functionability events have to be analysed within physical scale between 10^{-10} metre (to understand atom system based phenomena) and 10^{+10} metre (to understand phenomena driven by the solar system).

Observed patterns of the motion of a system functionability through business process shows that a large number of "identical" systems "are being functional" in accordance to a large number of different trajectories, while delivering "identical" functionality. Hence, the motion of system functionability through business process is of statistical nature, which requires the use of statistical methods for the calculation of statistical measures of the observed physical characteristics and properties of system functionability in time.

Day Two

Focuses on the mathematical formulations of the physical processes of the motion of system functionability through business processes. Mirce Functionability Formulas, developed by Dr J. Knezevic at the MIRCE Academy, define physical properties of system functionability in the probabilistic terms. Although the laws of probability are just as rigorous as other mathematical laws they are not able to predict the functionability trajectory for each individual system. They can only predict the probability of each individual system being in a given functionability state at a given instant of time or the collective probabilistic measures of the motion of a system functionability through given business processes and environment.

The probability of unity, for a system being functional at any instant of time during a given business process, the unit of functionability, is named 1 Senna in the memory of the great Formula 1 champion Ayrton Senna da Silva, (1960-1994)

Case Study 1: Business System Design

Best Business System Alternative is one that provides the best compromise among all competing business engineering alternatives regarding the functionality and functionability of the system considered against set business operational requirements and regulations. Some of them are directly related to the occurrence **failure events as the main drivers of the system reliability, maintainability and supportability**. Thus it is essential that failure **Mechanics, Causes, Modes, Diagnostics, Deferrals and Prognostics** issues are fully understood and incorporated into Bet design Strategy. However, as the majority of competing engineering issues are of numerical nature, all failure events related issue must be also expressed in quantitative manner. For that purpose the use of Mirce Functionability Formulas is essential. Thus, the participants will be actively engaged in the process of the selection of the Best Business System Engineering Alternative, among that tree shown below,

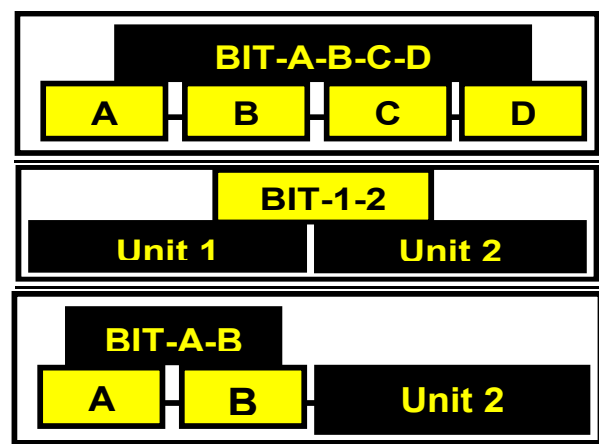

with the objective of addressing the following type of questions:

- **Which** is the best solution for the given design requirements and budget, **why** and by **how much**?
- Would you have chosen the same alternative, for example, for **Nigeria and Siberia**?
- Would you have chosen the same alternative, for example, for Siberia **in summer and winter**?

p.s. Please bring calculator or laptop as it will make your day more pleasant (but not compulsory)

Day Three

Focuses on the quantitative evaluation of Mirce Functionability Formulas for a given business system and given business process, rules and conditions, as the finding solutions to multi-dimensional integral equations is too complex to be solved analytically. Consequently, the participants will be introduced to the effective computational method that enables construction of models that accurately represent the observed reality of system behaviour, rather than to simplify system reality to cope with mathematical limitations is necessary. That is the Monte Carlo method, which has been very successful applied in Quantum Mechanics whose challenges are of similar nature to those of the Mirce Mechanics.

Day Four

It focuses on the demonstration of practical application of developed methods and technologies for the application of Mirce Functionability Formulas to:

System Design Process to enable the integrated design team to predict system functionability trajectory for each of feasible design alternatives at the conceptual stage of design, when changes are possible at least cost and time. Method of application is illustrated through the Case Study 1 (see previous page).

Day Five

It focuses on the demonstration of practical application of developed methods and technologies for the application of Mirce Functionability Formulas to:

System Operational Process to enable integration of operation, maintenance and logistics support policies for managing day to day flow of functionability, in respect to all feasible and mutually competing management alternatives, and predicting their impact on in-service reliability, cost and effectiveness, at the planning stages of system operational process. Method of application is illustrated through the Case Study 2

Case Study 2: System Operational Process

Best Operational Strategy is a set of chosen rules that describe **when, where, who and how** operational resources are planned, obtained, located and used to enable delivery of the system functionality during its specified interval of time. As chosen rules are based on the quantitative information related to the **system reliability, maintainability and supportability** characteristics, as well as the monetary values of the resources required for the execution of **operation, maintenance and logistics support** tasks, the selection process of the Best Operational Strategy require quantitative treatment of information available.

Participants will have opportunity to take an active part in the process of determination of the Best Operational Strategy for the 7 operational sites among three alternatives shown below, by making

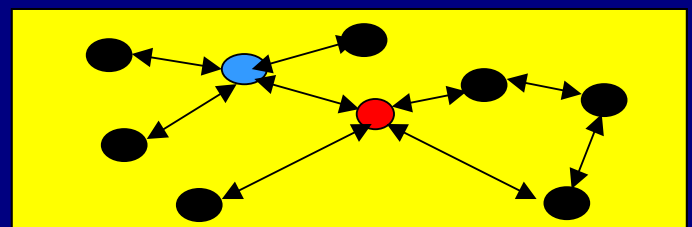
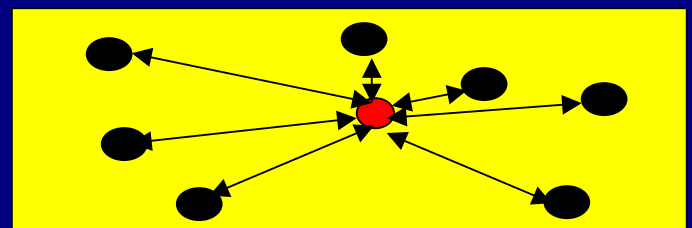
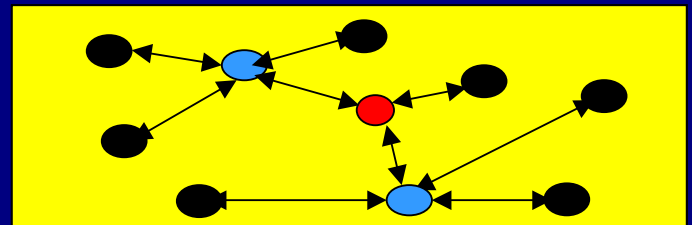

use of **Mirce Functionability Formula** in order to determine which is the **best Operational Strategy** and explain why and by how much.

p.s.

Please bring calculator or laptop as it will make your day more pleasant (but not compulsory)

Venue

Woodbury Park is a magnificent 500 acre leisure and sporting complex set among green rolling hills above the South West English coastline, only a few miles from the ancient city of Exeter.

Communication between Exeter and other parts of the United Kingdom are excellent.

By road, the M5 motorway links Exeter to London, the Midlands, Scotland and Wales. Regular rapid coaches run services to and from London and Heathrow Airport.

By rail, a regular fast service is available to and from Exeter (St David's Station) and London (Paddington Station).

By air, Exeter Airport, which offers regular flights to many British and Continental destinations is 5 miles from Woodbury Park.

Travel between Exeter and Woodbury requires a car or taxi and takes about thirty minutes. Among the outstanding leisure facilities at Woodbury Park are two golf courses including the magnificent Oaks Championship course, tennis courts, a swimming pool, spa, sauna and fully equipped keep fit centre.

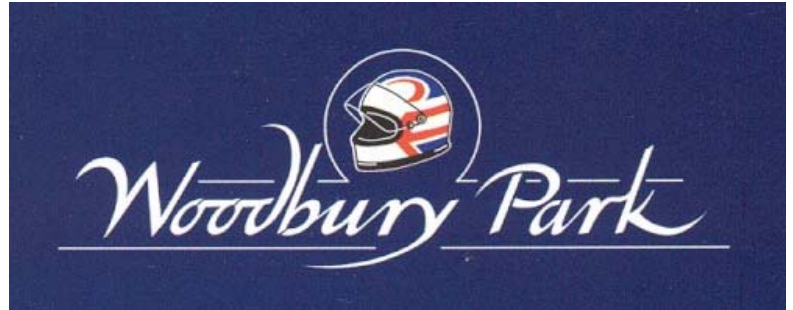

Woodbury Park is also home to the **Nigel Mansell World of Racing** that celebrates the remarkable career of one of the world's great champions and Grand Fellow of the MIRCE Akademy. The exhibition includes Formula 1 racing cars, video coverage of many outstanding racing achievements, in addition to trophies and memorabilia, marking Nigel Mansell's world-wide successes in the '92 Formula 1 and '93 Indy World Championships.



Key Information

Price (GB Pounds £)

Package Type	Fee	VAT	Total
Participant	1350.00	270.00	1620.00
MIRCE Fellows	1300.00	260.00	1560.00
MIRCE Member	1250.00	250.00	1500.00
MIRCE Student	1000.00	200.00	1200.00

The Price includes:

- Tuition
- Study Materials
- Lunches
- Light Refreshments
- Summer School Dinner on 7th July
- Visit to the Nigel Mansell World of Racing

Group Discounts for Standard Participants

Groups of 3 or more booking at the same time from the same organisation will receive a 15 % and for 5 or more there will be a 25% discount.

Location and Accommodation

The Summer School will be held at **Woodbury Park Hotel, Golf and Country Club**, which is approximately eight miles from Exeter by road.

Participants are responsible for the arrangement and payment of their own travel and accommodation.

Participants wishing to take advantage of preferential room rates should contact Woodbury Park Hotel Reservations quoting 'MIRCE'.

The contact details are:

Woodbury Park Hotel, Golf and Country Club,
Woodbury, Exeter, EX5 1JJ, United Kingdom

Tel +44 (0) 1395 233 382
Fax +44 (0) 1395 233 384
Email enquiries@woodburypark.co.uk
Web www.woodburypark.co.uk

A list of alternative accommodation in other hotels and guesthouses in the vicinity is available from MIRCE Akademy on request.

Travel

For travel details to Woodbury Park and a map visit our website at www.mirceakademy.com.

Messages

During the Summer School participants may be contacted by telephone on +44 (0) 1395 233 856 or by fax on +44 (0) 1395 233 899. Messages will be passed to participants during breaks.

Language

The Summer School language will be English.

Recommended Attire

Smart casual is recommended dress code for the Summer School and in the in the grounds of Woodbury Park.

No formal dress is required for the Summer School Dinner.

Smoking

Woodbury Park does not permit smoking in any of the leisure and sport complex facilities and in the hotel.

Mobile Phones

Out of consideration to speakers and the audience, mobile phones should be switched off during the formal sessions.

Further Information

 +44 (0) 1395 233 856
 +44 (0) 1395 233 899
 quest@mirceakademy.com
 www.mirceakademy.com

